

ENERGY PLUS COMMERCIAL WASHER



Featuring Factory-Installed Coin Slide and Coin Box



2013 Department of Energy Compliant
Modified Energy Factor: 1.85

Water Factor: 6.85

On average, uses 20 gallons per cycle—the
lowest water consumption for Whirlpool®
Commercial top-load washers.

FOR YOUR CUSTOMERS

- Large Capacity Wash Basket is Ideal for Family-Size Loads
- Proven Cleaning Performance
- Extra-Large Lid and Tub Opening
- 3 Cycle Options: Normal, Heavy Duty and Delicates for a Wide Range of Fabrics
- Separate Temperature Controls
- Ergonomic Control Knobs

AUTOMATIC LOAD SENSING

Adjusts water fill level based on load size, reducing water usage by up to 18 gallons per wash cycle.

BALANCE RING ADAPTER—CLOTHES GUARD

Discourages overloading and keeps small items out of the pump.

SECURE LID SYSTEM WITH SAFE RELEASE

To help ensure safe operation, the lid locks at start of cycle. Prevents damage when forced open.

INDUSTRIAL STRENGTH WATER INLET HOSES

- Tested to 1100 PSI
- Extra-Long 6' Hoses



CAE2743BQ—27" Commercial Washer

- 2.9-Cu.-Ft. Wash Basket
- Energy Plus, Low Water Factor
- 3 Cycles: Normal, Heavy Duty, Delicates
- Cycle Indicator LEDs
- Powdered Paint Top and Lid, Rustproof Stainless Steel Torx® Control Panel Screws
- Galvanized, Heavy-Gauge Cabinet Back, Side and Front Panels
- High-Speed Spin—700 RPM (maximum)
- 1/3 HP Motor
- Factory Coin Slide and Coin Box Equipped, \$1.50 Factory Preset Vend V8 Coin Slide
- Onboard Self Diagnostics
- Easy Adjustable Legs
- **90-Day Labor/2-Year Limited Parts Only Warranty***

*Call 1-800-662-3587 for warranty details.

ENERGY PLUS COMMERCIAL WASHER



Featuring Factory-Installed Coin Slide and Coin Box

Whirlpool® Energy Plus Commercial Washer Factory-Installed Coin Slide and Coin Box

WASHER SPECIFICATIONS	
MODEL	CAE2743BQ
GENERAL INFORMATION	
Modern design and look with all metal console and ergonomic control knobs. Automatic lid lock feature.	Large Capacity 2.9-Cu.-Ft. Basket
BASKET VOLUME	2.9 Cu. Ft.
MOTOR	
120 Volt, 1/3 HP, 1/4 kw, with thermal overload protection	Single-speed, permanent split capacitor, reversible motor
Spin RPM—Maximum	700
MAXIMUM RATED CURRENT—AMPS (VOLT)	8 (120)
ELECTRICAL REQUIREMENTS	120V, 60 Hz
Breaker/Fuse—AMPS	15
SHIPPING WEIGHT (EST.)	152 Lbs. Crated, 136 Lbs. Uncrated
DIMENSIONS	
Cabinet Width—in. (mm)	27 (686)
Cabinet Depth—in. (mm)	25.5 (648)
Cabinet Height—in. (mm) at Metercase Top	43 (1092)

Dimensions are for planning purposes only. For complete information, see installation instructions packed with product.

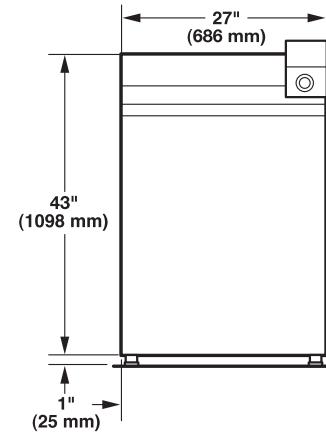

WASHER FRONT VIEW

NEW YORK CITY
M.E.A.

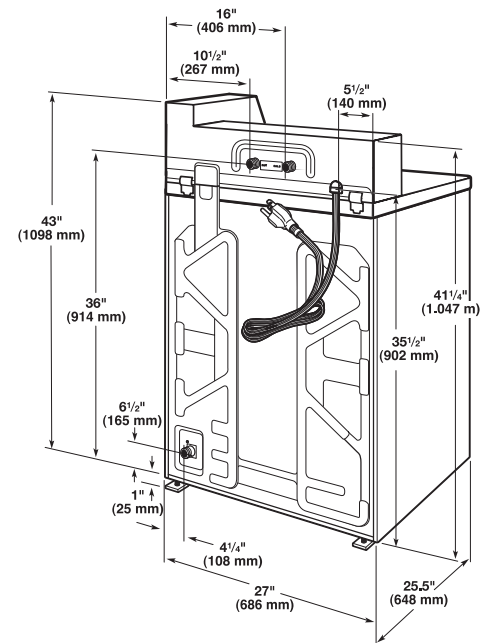

WASHER BACK VIEW



To Locate a Distributor Near You, Please Visit www.whirlpoolcommerciallaundry.com/distributor, or call 1-800-662-3587.